

AN2006-04

2ED100E12-F

Evaluation Driver Board for EconoDUAL™
IGBT Modules

AIM PMD ID AE

eupec
An Infineon brand



Never stop thinking

Edition 2006-11-20

**Published by
Infineon Technologies AG
59568 Warstein, Germany**

**© Infineon Technologies AG 2006.
All Rights Reserved.**

LEGAL DISCLAIMER

THE INFORMATION GIVEN IN THIS APPLICATION NOTE IS GIVEN AS A HINT FOR THE IMPLEMENTATION OF THE INFINEON TECHNOLOGIES COMPONENT ONLY AND SHALL NOT BE REGARDED AS ANY DESCRIPTION OR WARRANTY OF A CERTAIN FUNCTIONALITY, CONDITION OR QUALITY OF THE INFINEON TECHNOLOGIES COMPONENT. THE RECIPIENT OF THIS APPLICATION NOTE MUST VERIFY ANY FUNCTION DESCRIBED HEREIN IN THE REAL APPLICATION. INFINEON TECHNOLOGIES HEREBY DISCLAIMS ANY AND ALL WARRANTIES AND LIABILITIES OF ANY KIND (INCLUDING WITHOUT LIMITATION WARRANTIES OF NON-INFRINGEMENT OF INTELLECTUAL PROPERTY RIGHTS OF ANY THIRD PARTY) WITH RESPECT TO ANY AND ALL INFORMATION GIVEN IN THIS APPLICATION NOTE.

Information

For further information on technology, delivery terms and conditions and prices please contact your nearest Infineon Technologies Office (www.infineon.com).

Warnings

Due to technical requirements components may contain dangerous substances. For information on the types in question please contact your nearest Infineon Technologies Office.

Infineon Technologies Components may only be used in life-support devices or systems with the express written approval of Infineon Technologies, if a failure of such components can reasonably be expected to cause the failure of that life-support device or system, or to affect the safety or effectiveness of that device or system. Life support devices or systems are intended to be implanted in the human body, or to support and/or maintain and sustain and/or protect human life. If they fail, it is reasonable to assume that the health of the user or other persons may be endangered.

AN2006-04

Revision History:	2006-05	V1.0
--------------------------	---------	------

Previous Version:	none	
--------------------------	------	--

Author: Piotr Luniewski IFAG AIM PMD ID AE

Table of Contents		Page
1	Introduction	5
2	Datasheet	6
2.1	Main features	6
2.2	Key data.....	7
2.3	Pin assignment	8
2.4	Mechanical dimensions and mounting instructions.....	9
3	Application Note	10
3.1	Power Supply.....	10
3.2	Input logic – /PWM signals	10
3.3	Maximum switching frequency.....	11
3.4	Short circuit protection.....	12
3.5	Fault output.....	13
3.6	Temperature measurement	14
4	Schematic, Layout and Bill of Material	14
4.1	Schematic.....	15
4.2	Layout.....	18
4.3	Bill of Material	20
4.4	Gate resistors list	22

1 Introduction

The Evaluation Driver Board 2ED100E12-F was developed to support customers during their first steps designing applications with EconoDUAL™ -modules. The basic version of this board is available from Infineon in small quantities. The properties of this part are described in the datasheet chapter of this document whereas the remaining paragraphs provide information intended to enable the customer to copy, modify and qualify the design for production, according to his specific requirements.

The design of the 2ED100E12-F was performed with respect of the environmental conditions described as design target in the datasheet part. Also the requirements for leadfree reflow soldering have been considered when components were selected. The design was tested as described in this documentation but not qualified regarding manufacturing, operation in the whole operating ambient temperature range or lifetime.

The boards provided by Infineon are subjected to functional testing only.

Due to their purpose Evaluation Boards are not subjected to the same procedures regarding Returned Material Analysis (RMA), Process Change Notification (PCN) and Product Withdraw (PWD) as regular products.

See Legal Disclaimer and Warnings for further restrictions on Infineons warranty and liability.

Due to the Evaluation Driver Board's mounting position (Figure 1) and the internal module construction the 2ED100E12-F can ensure functional isolation only.

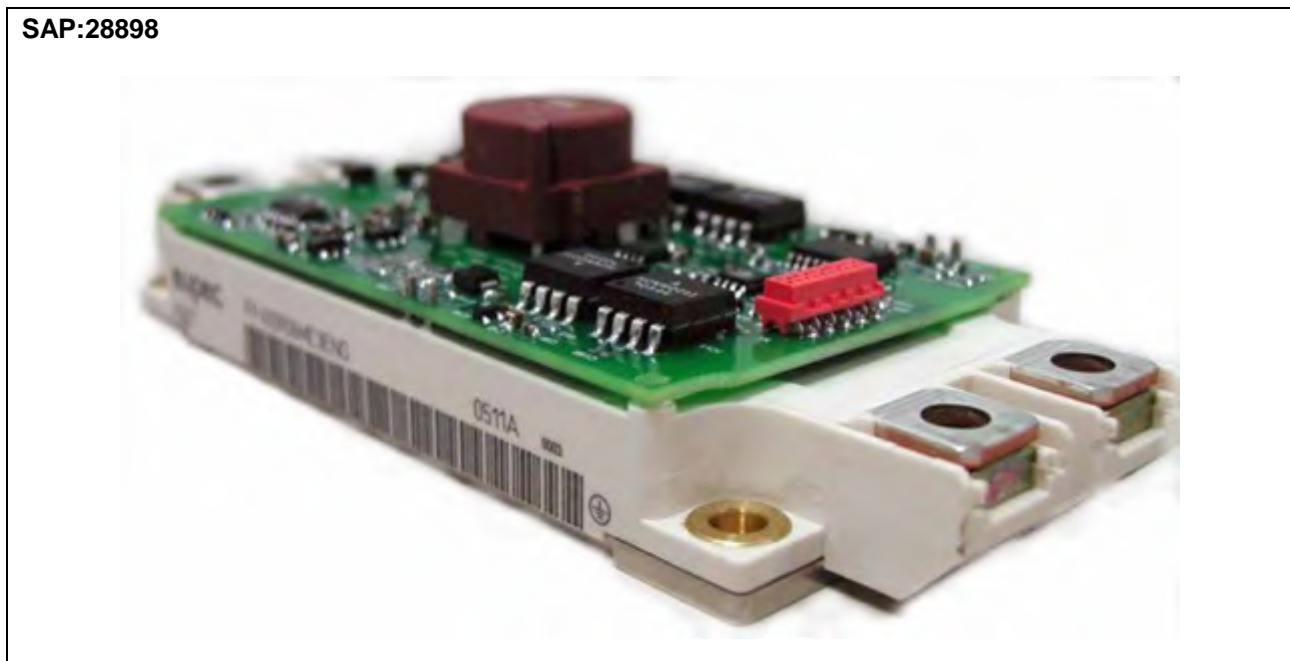

Figure 1 The 2ED100E12-F Evaluation Driver Board mounted on the top of the EconoDUAL™ module

2 Datasheet

2.1 Main features

The 2ED100E12 Evaluation Driver Board offers the following features:

- Dual channel IGBT driver
- Electrically and mechanically suitable for 600V and 1200V EconoDUAL™ IGBT modules
- Integrated and protected against short circuit DC/DC power supply,
- Integrated protection against DC/DC power supply short circuit
- Isolated temperature measurement with broken wire detection
- Short circuit protection using 2-level Turn-off technique ($T_{off} < 6\mu s$)
- Under Voltage Lockout
- Negative logic with CMOS logic level (5V) for PWM and Fault signals. Can be converted to positive logic
- Common fault output signal for Top and Bottom IGBT
- PCB is designed to fulfil the requirements of IEC61800-5-1 (pollution degree 2, overvoltage category III)

2.2 Key data

All values given in the table below are typical values, measured at Ta=25°C

Table 1 Key data and characteristic values

Parameter	Value	Unit
V _{DC} – primary DC/DC voltage supply	+15 (±0.5)	V
V _{PWM} – /PWM signals for Top and Bottom IGBT (active low)	0/+5	V
V _{FAULT} – /FAULT detection output (active low)	0/+5	V
I _{FAULT} – max. /FAULT detection output load current	4	mA
I _{DC} – primary DC/DC current drawn (idle mode/max load)	55/315	mA
V _{out} – drive voltage level for Top and Bottom channel	+16/-8	V
I _G – max. peak output current	±10	A
P _{DC/DC} – max. DC/DC output power (Top channel + Bottom channel)	3	W
R _{Gmin} – min. gate resistor value (internal module resistor R _{INT} + external R _{EXT})	2.4	Ω
f _S – max. PWM signal frequency for Top and Bottom channel ¹⁾	100	kHz
t _{pd(on)} , t _{pd(off)} – propagation delay time ²⁾	<800	ns
t _{md} – minimum pulse suppression for turn-on and turn-off ³⁾	100	ns
d _{max} – max. duty cycle	100	%
V _{CES} – max. collector – emitter voltage on IGBT	1200	V
V _{TEMP} – temperature measurement output voltage	0...+5	V
I _{TEMP} – max. temperature measurement load current	5	mA
T _{op} – operating temperature (design target) ⁴⁾	-40...+85	°C
T _{sto} – storage temperature (design target)	-40...+85	°C
V _{IORM} – max. working insulation voltage ⁵⁾	500	V _{AC}

¹⁾ The maximum switching frequency for every EconoDUAL™ module type should be calculated separately. Limitation factors are: max. DC/DC output power (1.5W per channel) and max. PCB board temperature measured around gate resistors (105°C for FR4). For detailed information see chapter 2.3

²⁾ Only if 2-level Turn-off function is disabled. See chapter 2.4

³⁾ Min. value tonmin given in TD350 IGBT driver datasheet (August 2004, Revision 1)

⁴⁾ Max. ambient temperature strictly depends on load and cooling conditions. For detailed description see chapter 2.3

⁵⁾ Values defined in datasheets: T60403-D4615-X054 (date: 21.03.2000), HCNW2211 (February 28, 2005), AD7400 (1/06 – Revision 0: Initial version)

2.3 Pin assignment

All external signals should be applied to connector X1, they are shown on Fig. 2 and the description is given in Table 2.

Table 2 Inputs and outputs of 2ED100E12-F (connector X1)

Pin	Label	Function
X12, X14	V _{DC}	Primary voltage supply for DC/DC converter
X18	/PWMT	PWM signal for Top transistor
X110	/PWMB	PWM signal for Bottom transistor
X16	TEMP	Temperature measurement output
X17	/FAULT	Fault detection output
X11, X13, X15,	GND	Primary ground for DC/DC converter supply voltage
X19	GND	Primary ground for input/output signals (/PWMT, /PWMB, TEMP, /FAULT)

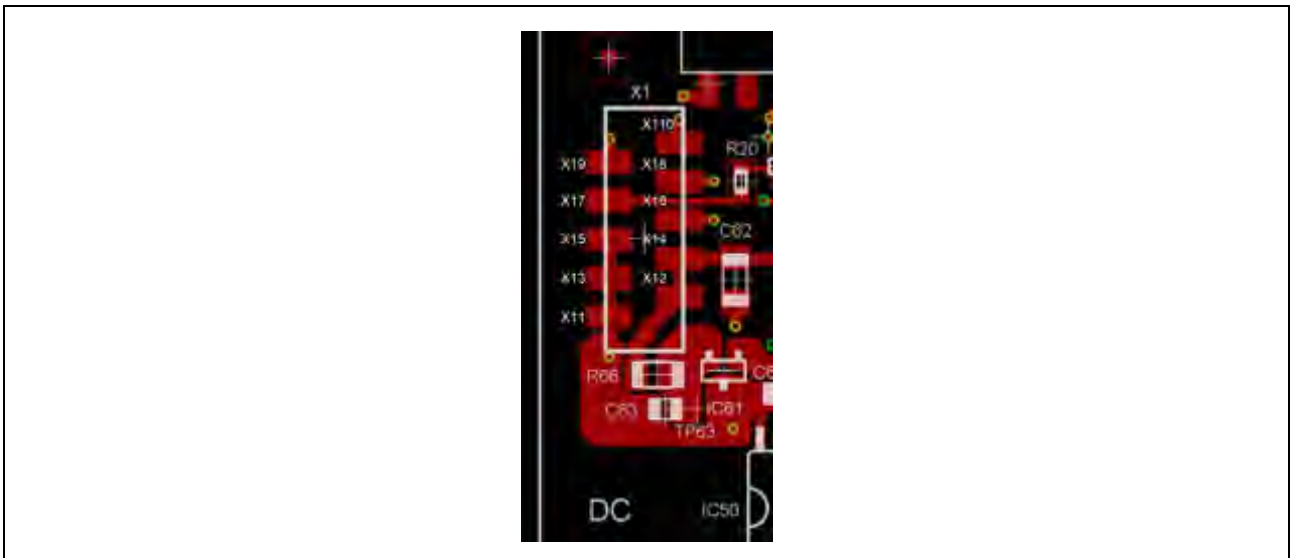

Figure 2 The 2ED100E12-F Evaluation Driver Board pin assignment

2.4 Mechanical dimensions and mounting instructions

The 2ED100E12-F should be fastened by self tapping screw and soldered to the auxiliary connectors on the top of the EconoDUAL™ IGBT module. Detailed information available in application note (AN2006-05).

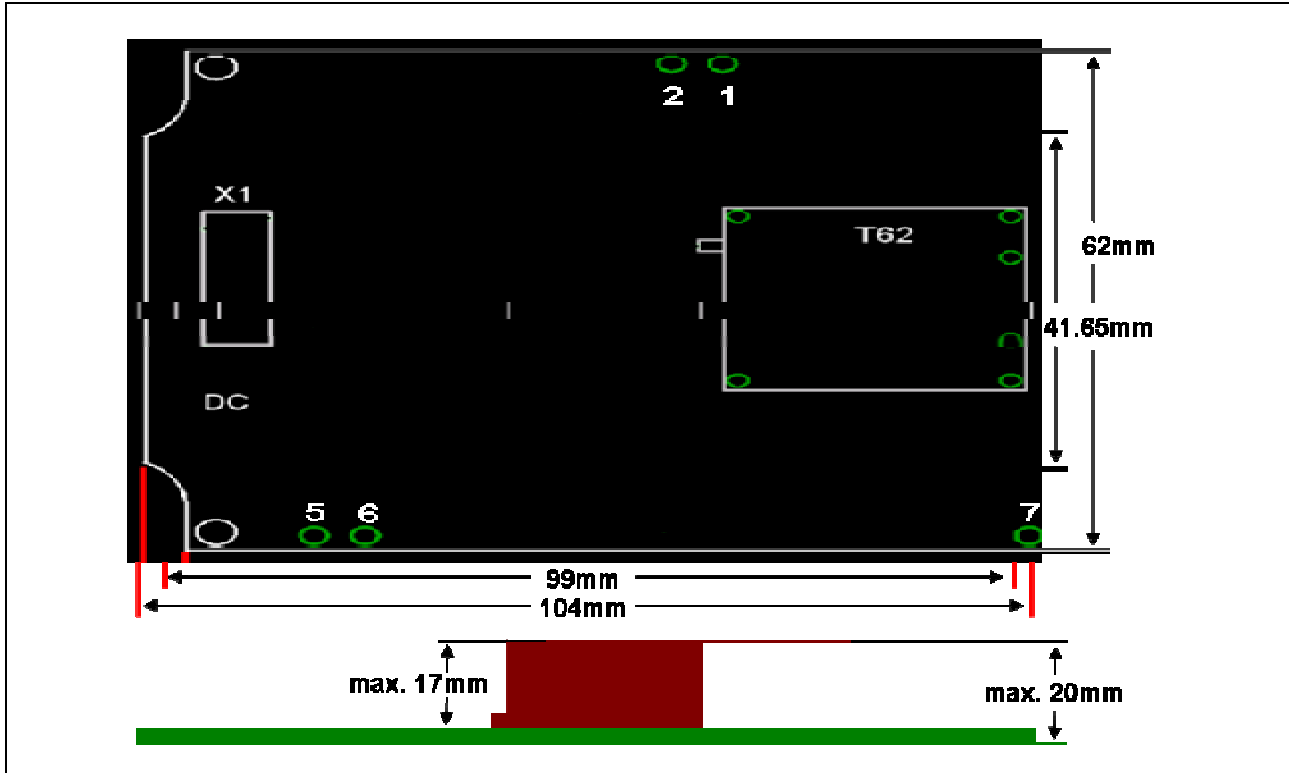

Figure 3 Dimensions of the 2ED100E12-F

Clearance distance and creepage between Primary/Secondary is not less than 8mm

Clearance distance and creepage Secondary/Secondary is not less than 7mm

3 Application Note

3.1 Power Supply

The 2ED100E12-F has an integrated DC/DC converter, which generates the required secondary isolated unsymmetrical supply voltage (+16V/-8V). Top and Bottom driver voltages are independently generated by using one unipolar input voltage of 15V. Additionally, the power supply is protected against gate – emitter short circuit of the IGBTs. In case a DC/DC overcurrent is detected, the output voltage drops down, the IGBT is protected by Under Voltage Detection function and the fault is reported to the isolated 2ED100E12-F side.

3.2 Input logic – /PWM signals

The Evaluation Driver Board is dedicated for a half-bridge EconoDUAL™ IGBT configuration, therefore it is necessary to connect two separate PWM signals for Top (/PWMT) and Bottom (/PWMB) IGBT. The signals need to have the correct dead time. The 2ED100E12-F does not provide automatic dead time generation and recommended minimal dead times t_{TD} are given in Table 3.

The /PWM input logic can be changed to positive logic during the assembly process or manually by replacing the original components.

Assembly for negative PWM logic:

R_1, R_{10} - 22k Ω ; IC₁, IC₁₀ – SN74LVC1G14DCKR;

R_3, R_{13} are not assembled.

To obtain the positive PWM logic the necessary changes are: R_1, R_{10} – not assembled;

R_3, R_{13} - 22k Ω , IC₁, IC₁₀ – SN74LVC1G17DCKR;

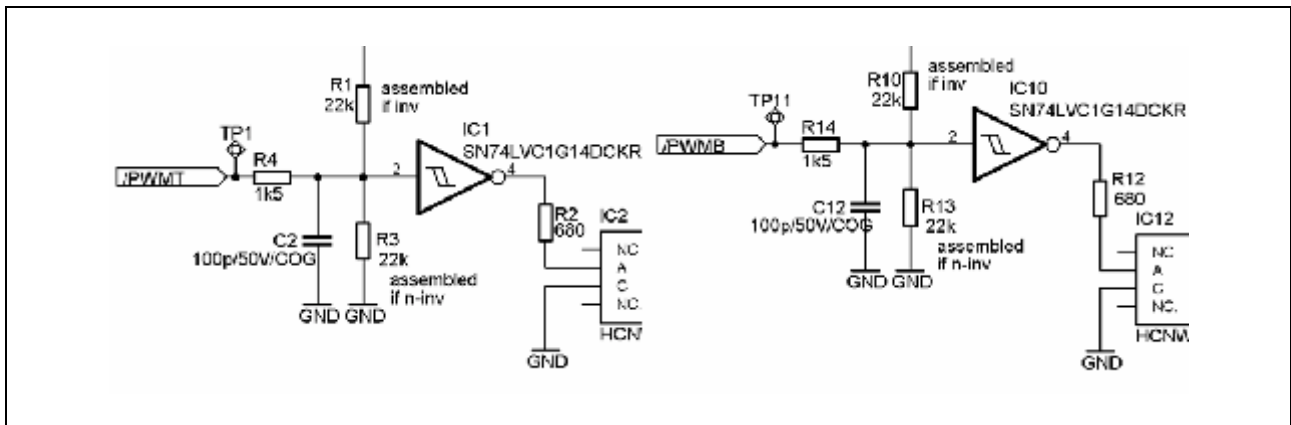

Figure 4 Schematic of the input circuit.

3.3 Maximum switching frequency

The IGBT switching frequency is limited by the available DC/DC power and by PCB temperature. Accordingly to theory the power losses generated in gate resistors are a function of gate charge, voltage step at the driver output and switching frequency. The energy is dissipated mainly through the PCB and increases the temperature around the gate resistors. When the available power of the DC/DC is not reached, the limiting factor for the IGBT's switching frequency is the absolute maximum temperature for the FR4 material. The temperature is 105°C and shall not be exceeded.

Generally the power losses generated in the gate resistors can be calculated according to following formula (1):

$$P_{dis} = P(R_{EXT}) + P(R_{INT}) = \Delta V_{out} \cdot f_s \cdot Q_G \quad (1)$$

where:

P_{dis} – dissipated power, ΔV_{out} – voltage step at the driver output

f_s – switching frequency, Q_G – IGBT gate charge (value given for a range of gate voltage level)

The losses are shared between the internal – $P(R_{INT})$ and the external - $P(R_{EXT})$ gate resistors. Due to the PCB temperature criteria the power of the external gate resistor $P(R_{EXT})$ is the interesting value when the thermal resistance is given.

Based on experimentally determined board temperature dependencies $T_{PCB} \sim P(R_{EXT})$ (Figure 5) it is possible to determine the maximal IGBT switching frequency, if the power losses of the external gate resistor and the max. ambient temperature are known.

As can be concluded from Figure 5, the board can dissipate approximately 0,29W from the external gate resistors soldered to PCB at $T_a=85^\circ\text{C}$. The max. switching frequency for this condition is 15kHz. It is possible to increase the switching frequency up to 35kHz when the ambient temperature is decreased to 70°C. Under these conditions the board can dissipate approximately 0,6W. At room temperature the 2ED100E12-F can drive the IGBTs safely with the switching frequency limited by the available power of the DC/DC (1.5W).

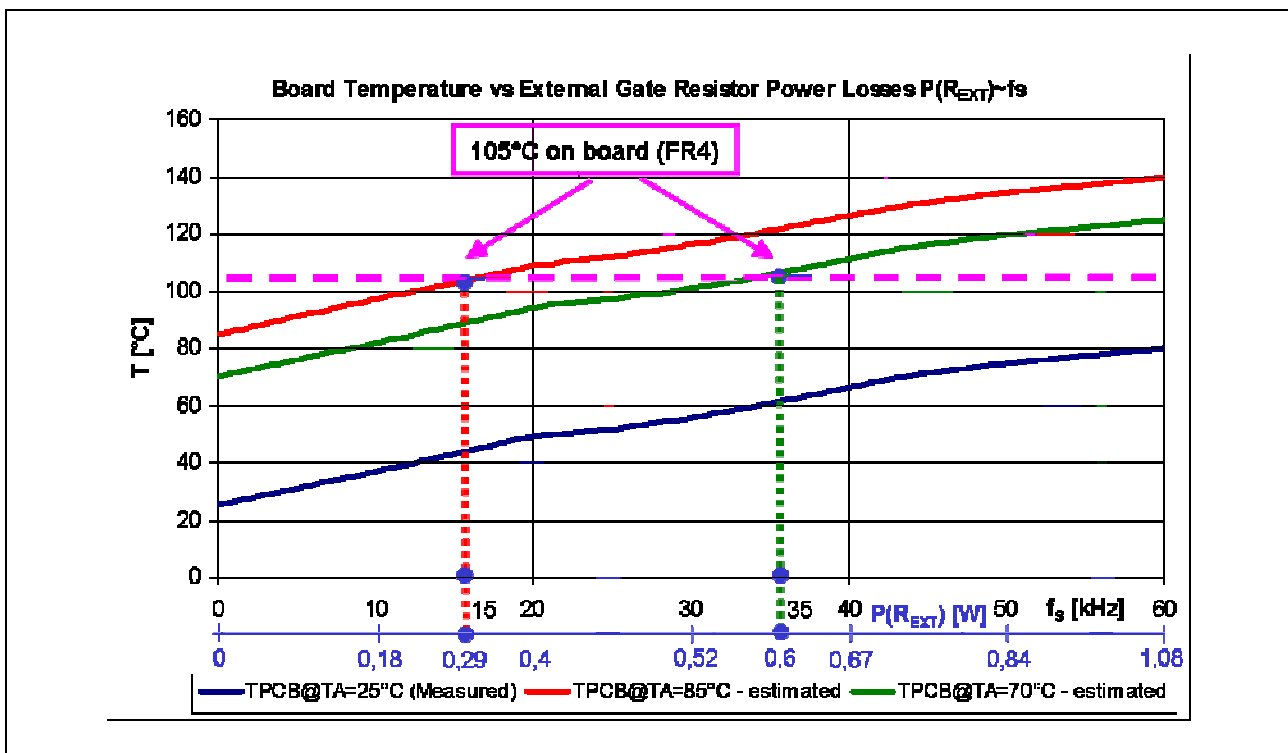

Figure 5 PCB temperature vs gate resistor power losses and switching frequency (FF225R12ME3)

The curve from Figure 5 can be used for max. switching frequency estimation of EconoDUAL™ modules as is listed below:

Table 3 Estimated max. IGBT switching frequency and PWM minimum dead times for 2ED100E12-F and EconoDUAL™ modules

Module	R _{EXT} [Ω]/R _{INT} [Ω]	f _s @Ta=25°C	f _s @Ta=70°C	f _s @Ta=85°C	t _{TD} (dead time)
FF450R06ME3	1,5 /	no Q _G data			
FF600R06ME3	3,0 / 0,7	15 kHz – limited by DC/DC power	7 kHz	3,3 kHz	1μs
FF150R12ME3	8,2 / 1,3	70 kHz – limited by DC/DC power	31 kHz	14 kHz	1μs
FF225R12ME3	3,3 / 3,3	45 kHz – limited by DC/DC power	35 kHz	15 kHz	1μs
FF300R12ME3	2,4 / 2,5	35 kHz – limited by DC/DC power	28 kHz	13 kHz	1μs
FF450R12ME3	1,6 / 1,7	22 kHz – limited by DC/DC power	17 kHz	8 kHz	1μs
FF150R12MS4	7,5 / 1,7	60 kHz – limited by DC/DC power	28 kHz	13 kHz	1μs
FF225R12MS4	4,7 / 1,7	40 kHz – limited by DC/DC power	20 kHz	9 kHz	1μs
FF300R12MS4	2,7 / 1,7	30 kHz – limited by DC/DC power	18kHz	8 kHz	1μs

3.4 Short circuit protection

The short circuit protection of the Evaluation Driver Board basically relies on 2-level Turn-off function already implemented in the TD350. Thanks to this operation mode, the collector-emitter overvoltage, which is a result of the stray inductance and the collector current slope, is limited⁶⁾. This requires appropriate setting of T_a and the second level of the turn-off voltage. If the stray inductance is not higher than 30μH the 2ED100E12-F can switch-off the IGBT safely. If L_{σ} is bigger, an additional adjustment of R_{5T}, R_{5B}, C_{5T}, C_{5B}, D_{6T} and D_{6B} (Figure 6a, 6b) must be performed. The typical waveforms of a FF225R12ME3 module with optimized 2-level Turn-off circuit, during switching-off under short circuit condition are shown on Figure 6c.

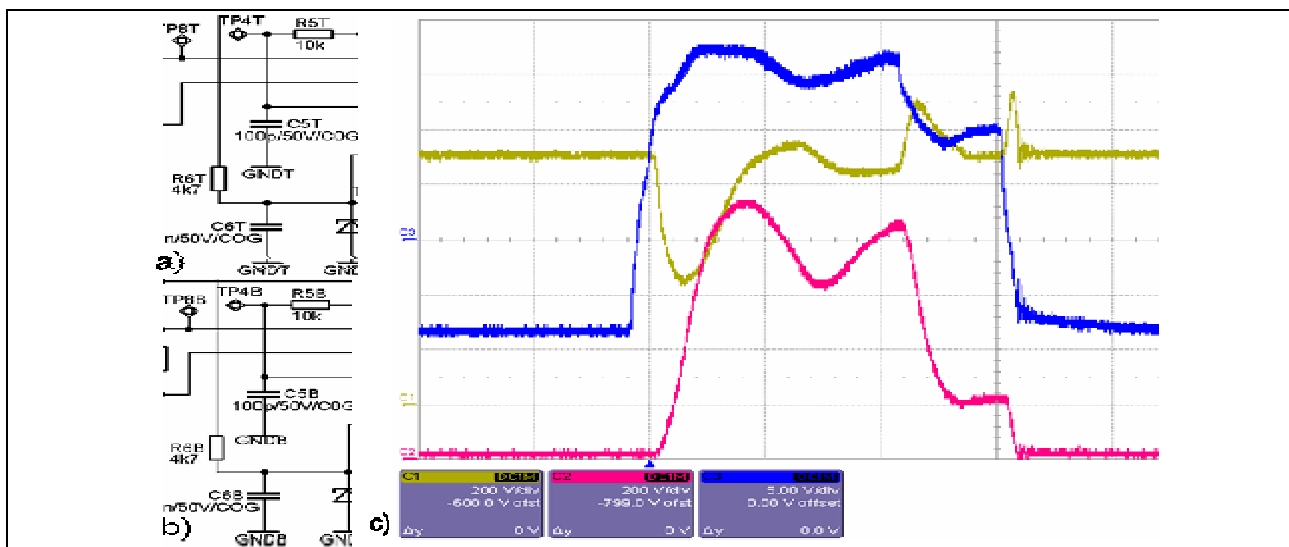

Figure 6 a, b) 2-level Turn-off circuit with values to be adjusted if $L_{\sigma} > 30\text{nH}$, c) switching-off under short circuit conditions

Note that the 2-level Turn-off on the Evaluation Driver Board is always enabled, therefore the propagation delay time $t_{pd(on)}$ and $t_{pd(off)}$ are extended by the time T_a . During normal operation the delay time can be calculated as $t_{pd} + T_a$ and equals approximately 1,5μs.

⁶⁾ Detailed information about this function available in: TD350 datasheet and AN1944

3.5 Fault output

When short circuit occurs, the voltage V_{GE} is controlled by the 2-level Turn-off circuit and the IGBT is switched-off. The fault is reported to the isolated side of the driver as long as the active level of PWM signal is applied (see Figure 8). It is absolutely necessary that after failure reporting the PWM generator will not send PWM pulses in time intervals shorter than 50ms, make sure that the junction temperature does not rise above 150°C otherwise the module might be destroyed. The /FAULT signal has a negative logic but can be changed to positive logic during the assembly process or after a modification. To change the logic to positive logic the SN74LVC1G97DCKR (IC₂₀) should be replaced by SN74LVC1G98DCKR (Figure 7).

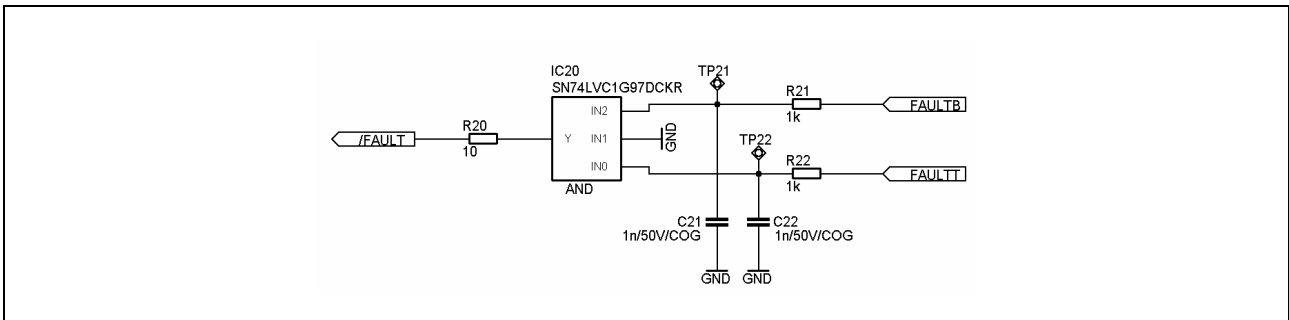

Figure 7 /Fault output

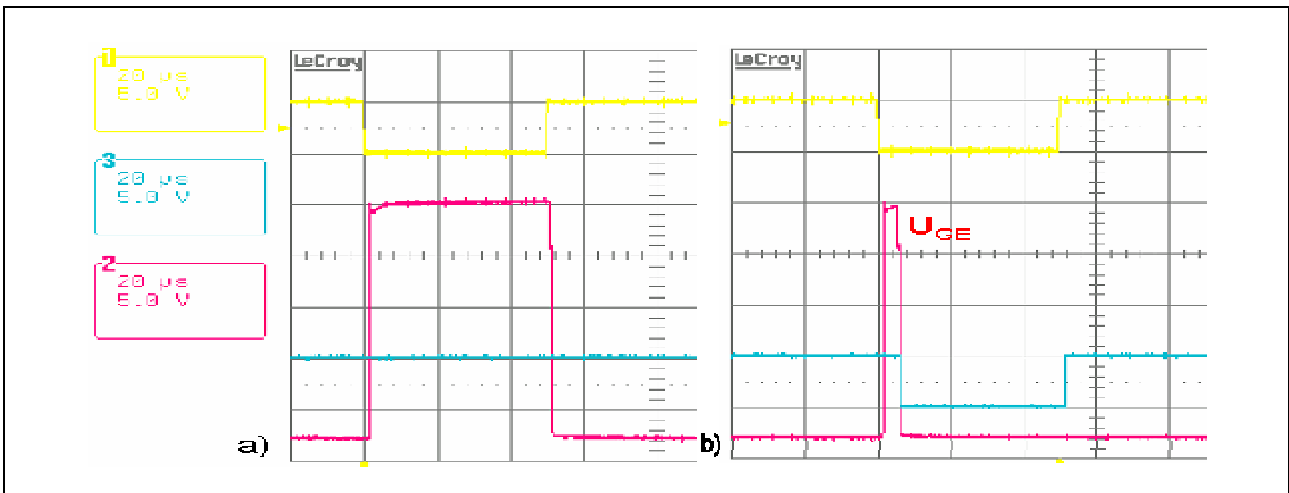

Figure 8 /Fault output during: a) normal operation, b) operation under short circuit

3.6 Temperature measurement

Based on the NTC built into the EconoDUAL™ modules, the 2ED100E12-F offers IGBT base plate temperature measurement in the range of -40°C ... 150°C . Under the assumption that the junction temperature is equal to the base plate temperature the junction temperature can be estimated. Output voltage vs. base plate temperature is shown on Figure 9.

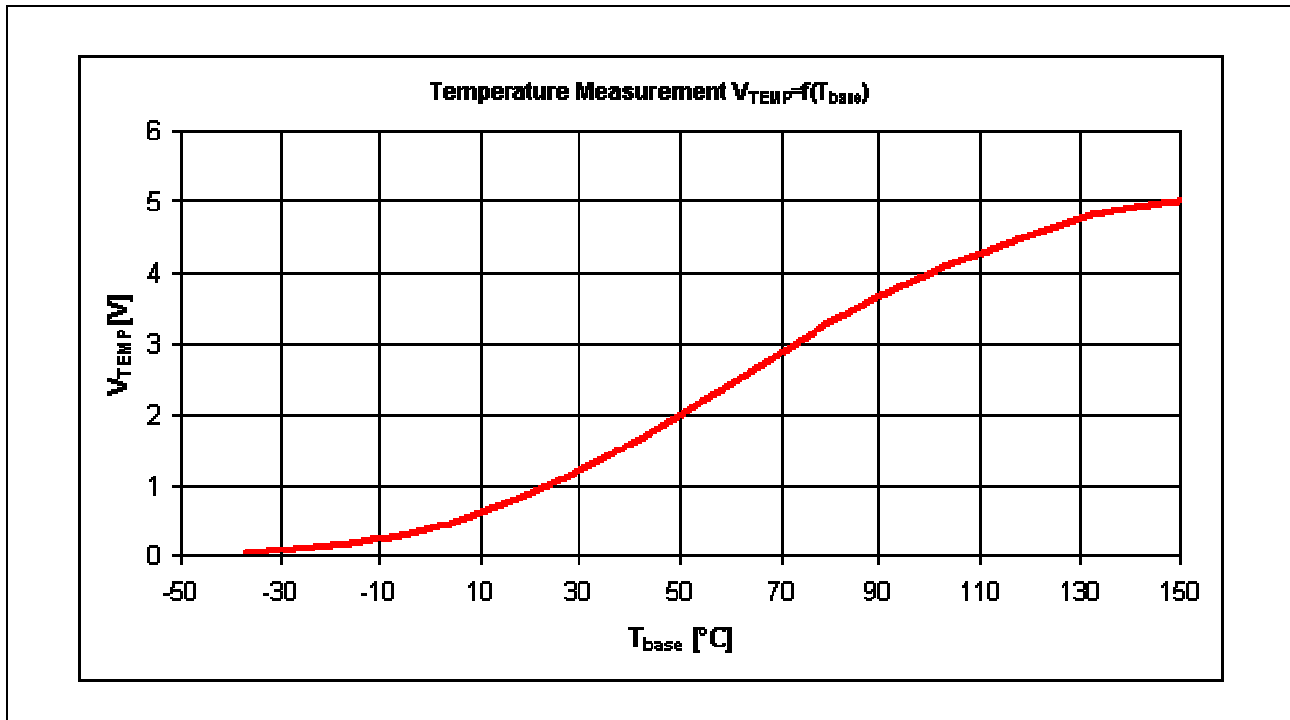

Figure 9 Characteristic of the temperature measurement

Note: This temperature measurement is not suitable for short circuit and may be used to protect the module from long term overload conditions or malfunction of the cooling system.

4 Schematic, Layout and Bill of Material

To meet the individual customer requirement and make the Evaluation Driver Board simple for development or modification, all necessary technical data like schematic, layout and components are included in this chapter.

4.1 Schematic

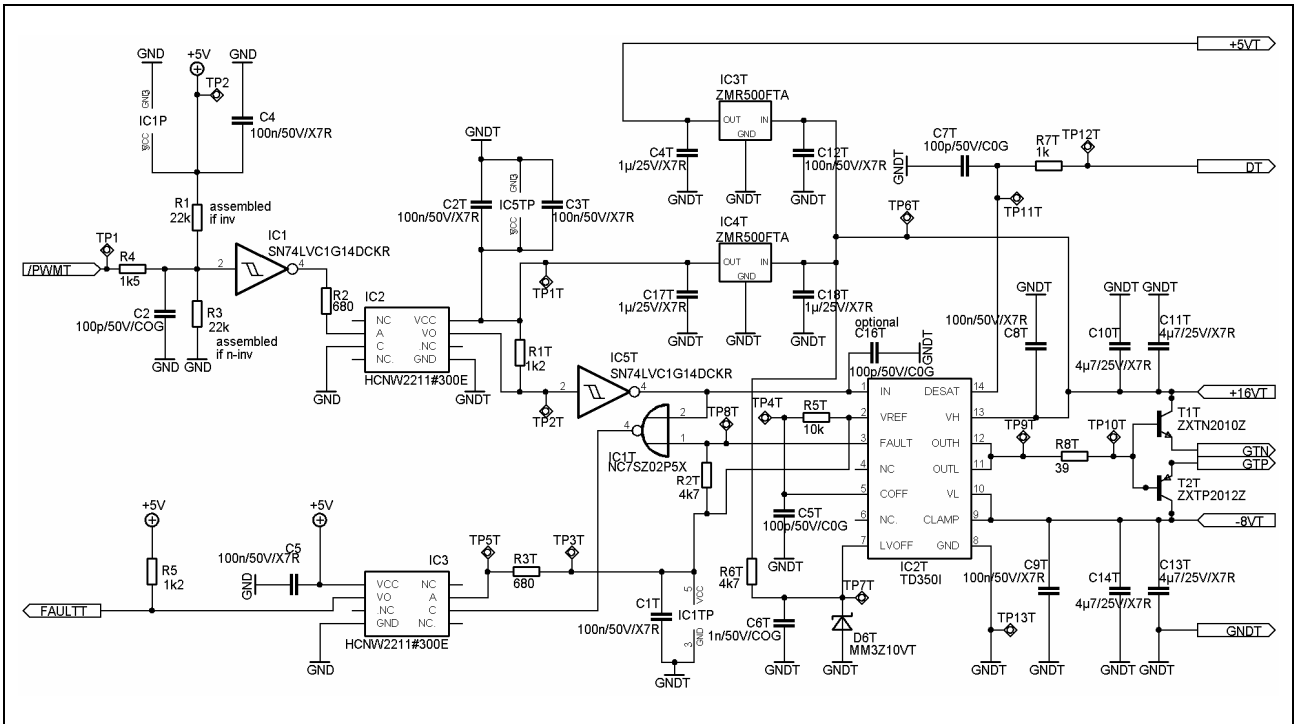

Figure 10 IGBT driver – Top transistor

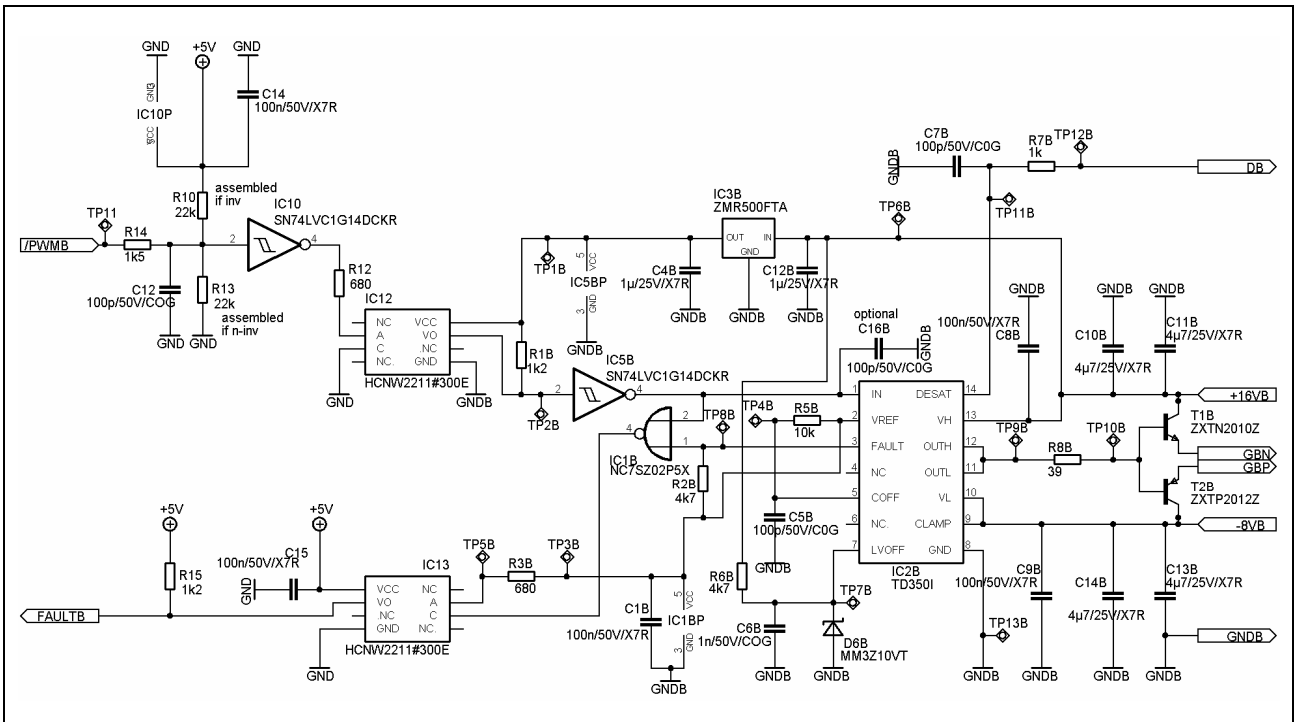

Figure 11 IGBT driver – Bottom transistor

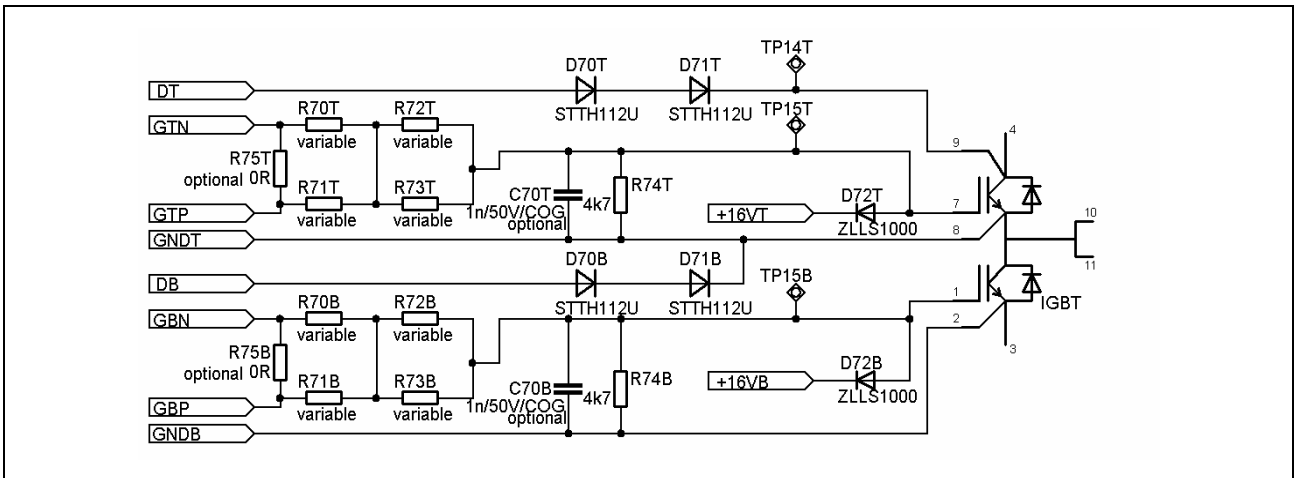

Figure 12 IGBT driver – Module connectors

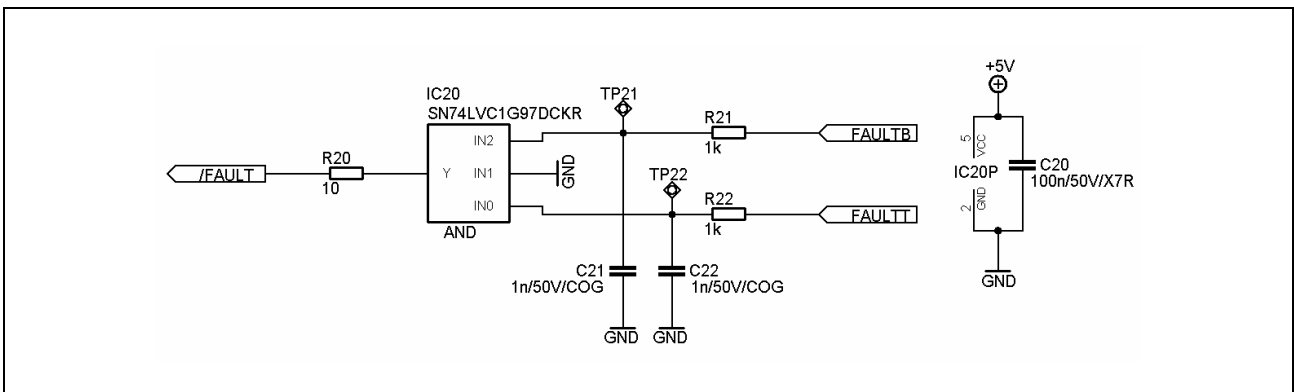

Figure 13 IGBT driver – Fault output

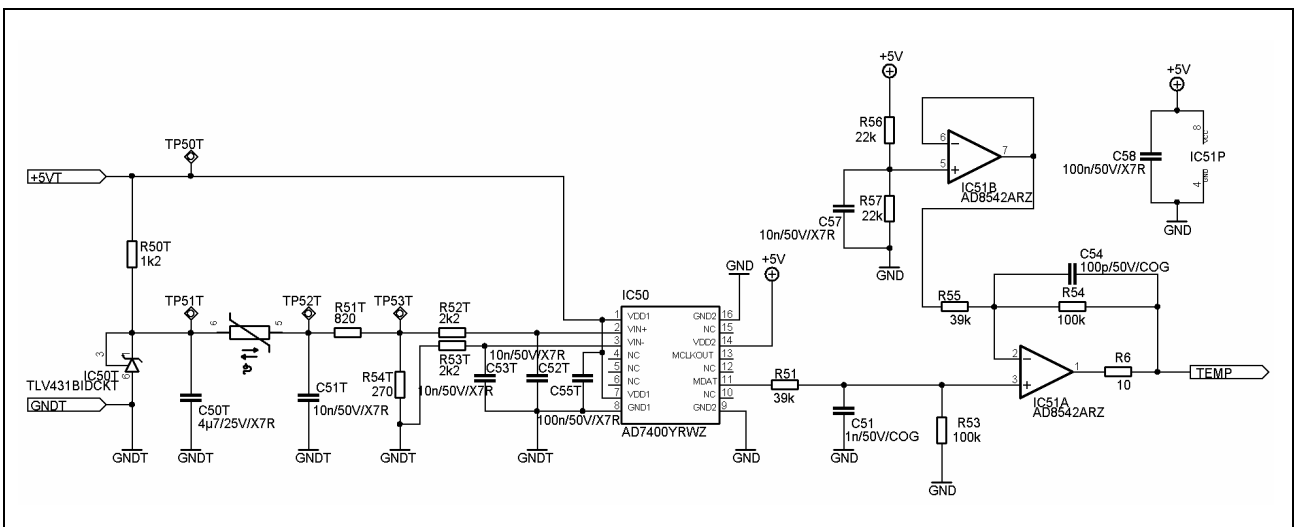

Figure 14 IGBT driver – Temperature measurement

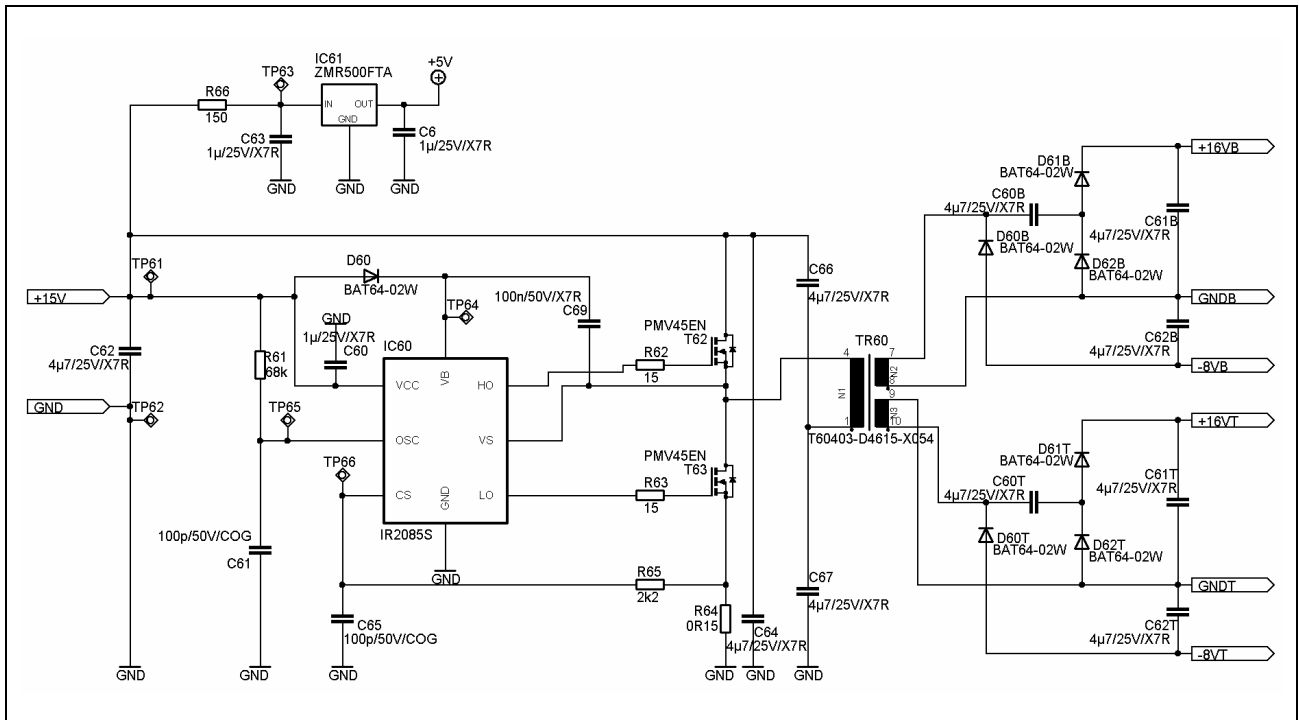

Figure 15 IGBT driver – DC/DC converter

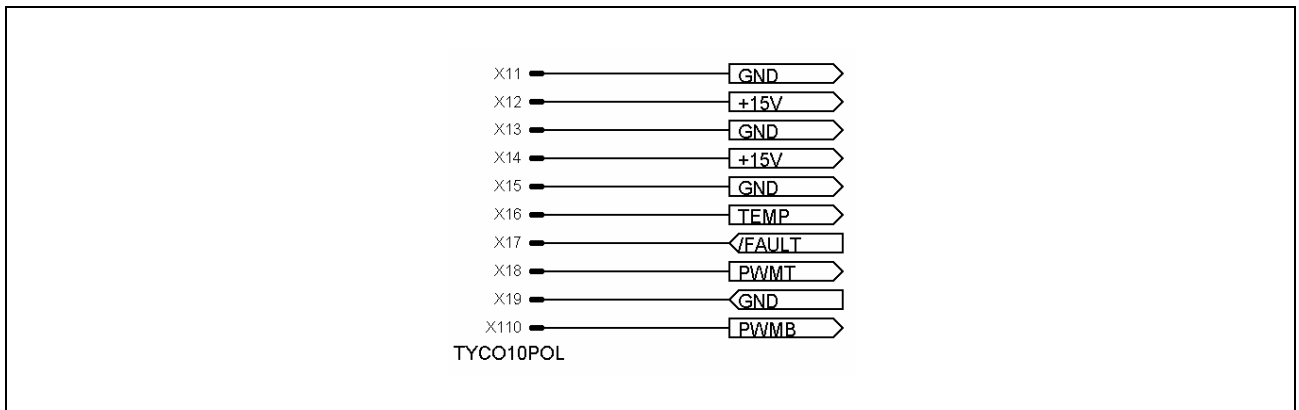

Figure 16 IGBT driver – External connections

4.2 Layout

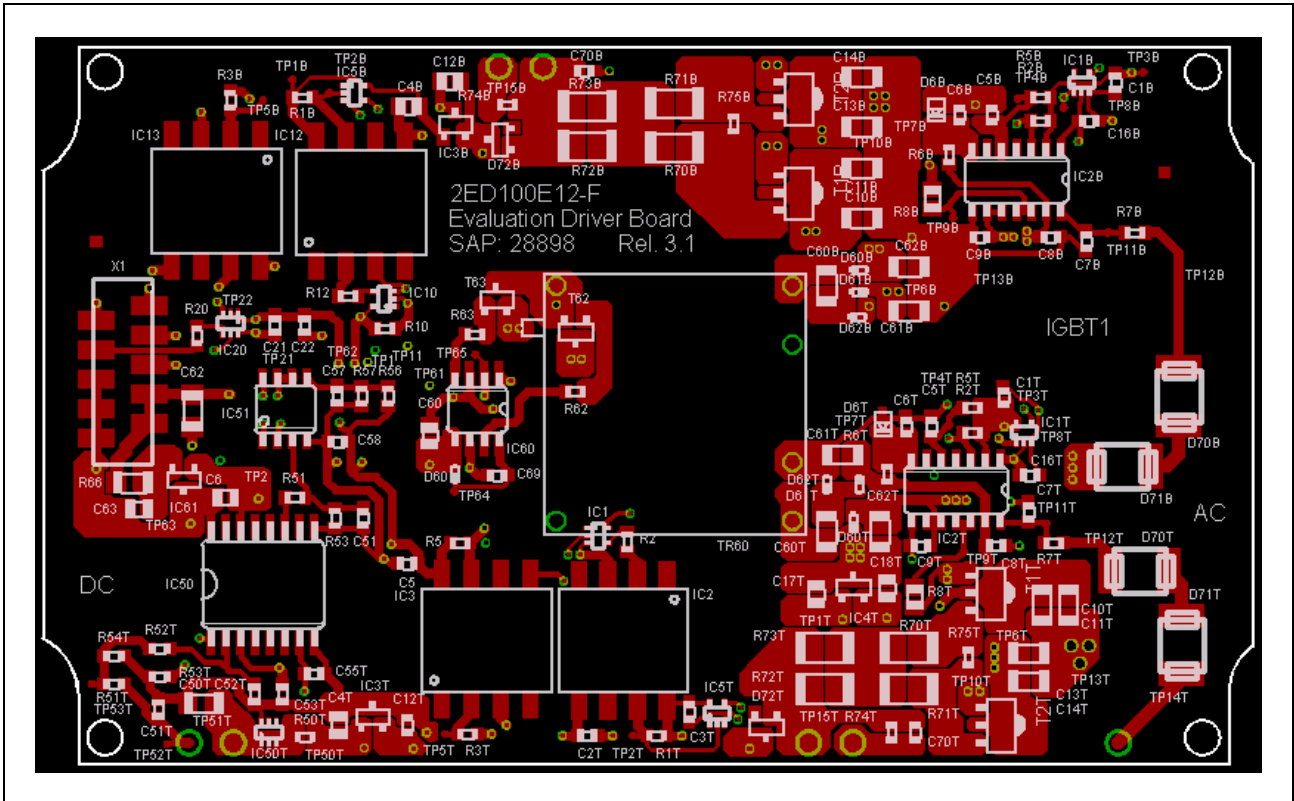

Figure 17 IGBT driver – Layer 1 (Top)

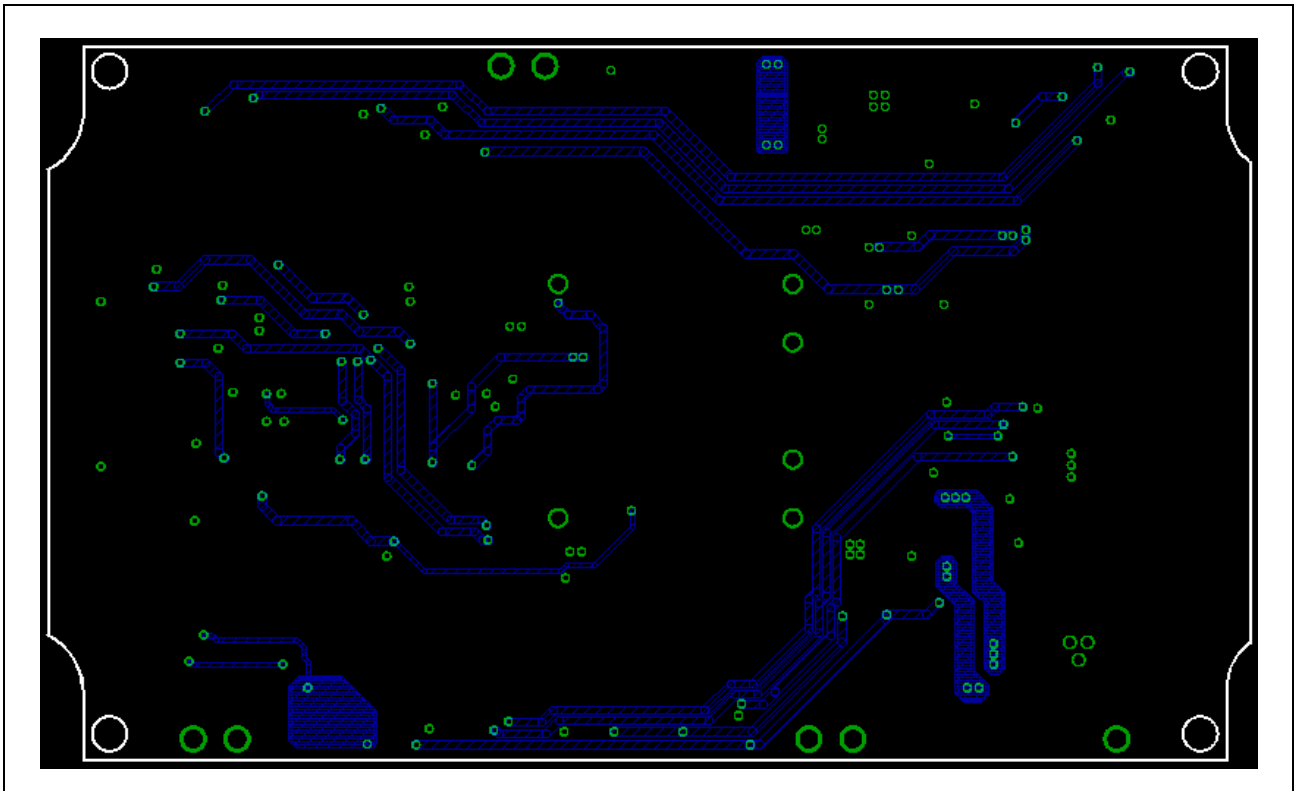

Figure 18 IGBT driver – Layer 2

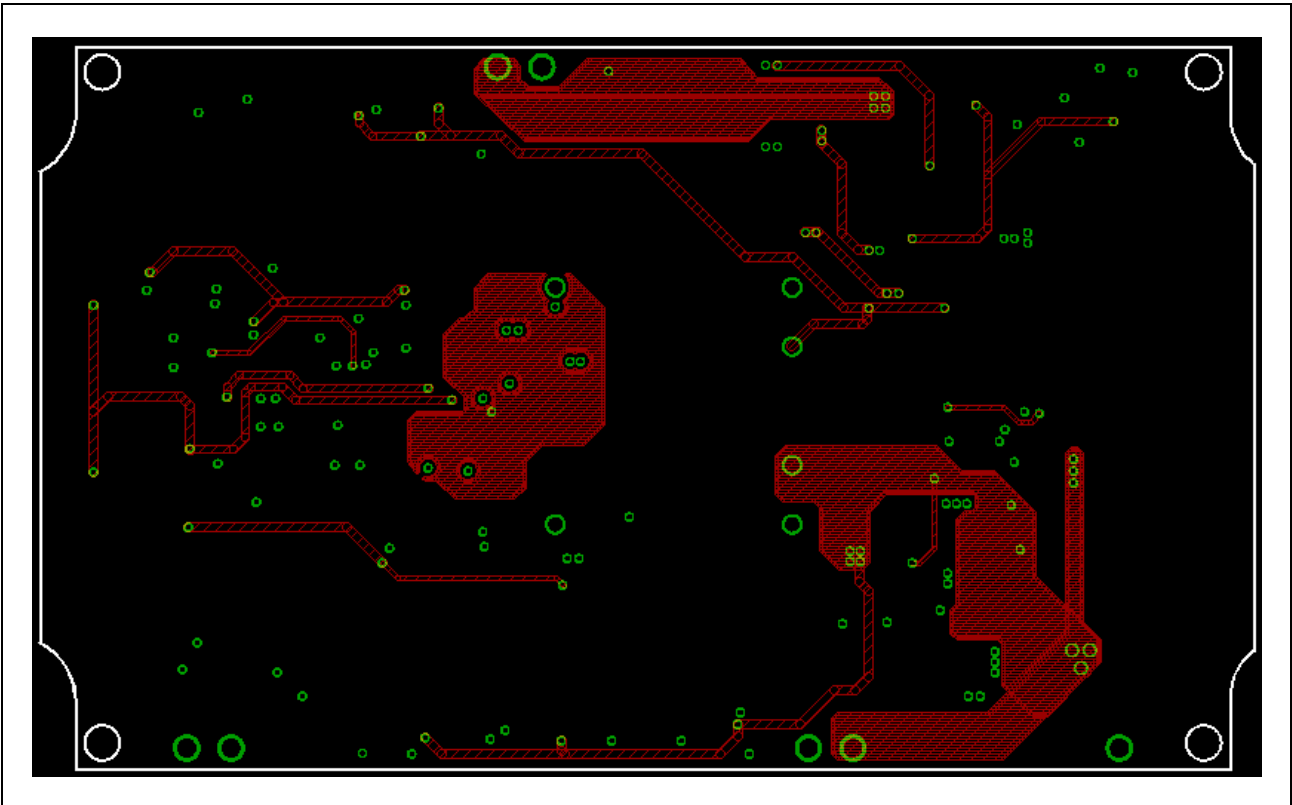

Figure 19 IGBT driver – Layer 3

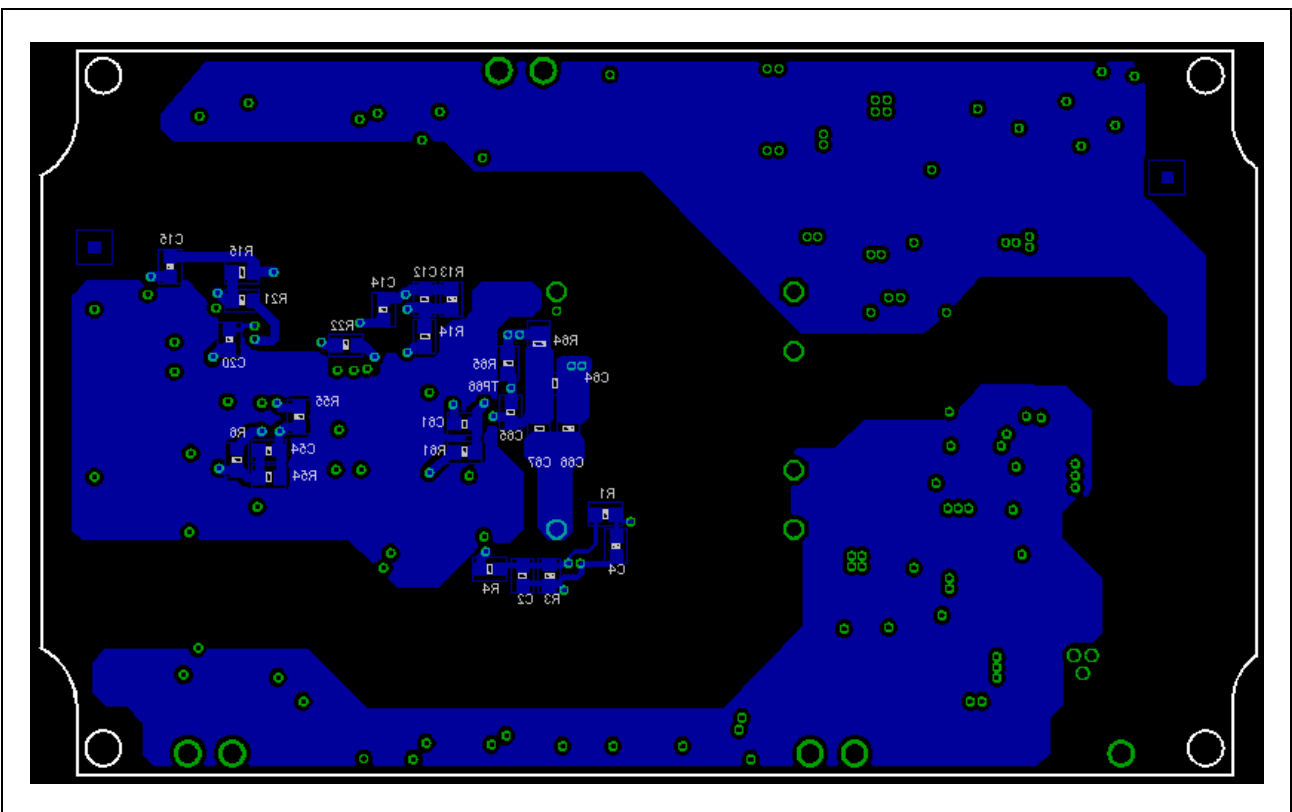

Figure 20 IGBT driver – Layer 4 (Bottom)

4.3 Bill of Material

The bill of material includes not only a part list, but also assembly notes. All electronic parts used in the design, except the DC/DC transformer, are lead-free with 260°C soldering profile. The external gate resistors are not assembled, a list for the resistor values is presented in chapter 3.4.

Table 4 Bill of Material

Type	Value / Type	Package	Name Part	Recommended Manufacturer	Comment	Assembly
Resistor	0R	0603	R75B, R75T	no special		yes
Resistor	0R15	0805	R64	no special		yes
Resistor	to be chosen individually	2010	R70B, R70T, R71B, R71T	no special	value depends on the module	no
Resistor	to be chosen individually	2010	R72B, R72T, R73B, R73T	no special	value depends on the module	no
Resistor	10R	0603	R6, R20	no special		yes
Resistor	15R	0603	R62, R63	no special		yes
Resistor	39R	0805	R8B, R8T	no special		yes
Resistor	150R	1206	R66	no special		yes
Resistor	270R	0603	R54T	no special		yes
Resistor	680R	0603	R3B, R3T, R2, R12	no special		yes
Resistor	820R	0603	R51T	no special		yes
Resistor	1k	0603	R7B, R7T, R21, R22	no special		yes
Resistor	1k2	0603	R1B, R1T, R50T, R5, R15	no special		yes
Resistor	1k5	0603	R4, R14	no special		yes
Resistor	2k2	0603	R52T, R53T, R65	no special		yes
Resistor	4k7	0603	R2B, R2T, R6B, R6T, R74B, R74T	no special		yes
Resistor	10k	0603	R5B, R5T	no special		yes
Resistor	22k	0603	R1, R10, R56, R57	no special	R1, R10 assembled if IC1 and IC10 are inverters SN74LVC1G14DCKR	yes
Resistor	22k	0603	R3, R13	no special	assemble if IC1 and IC10 are SN74LVC1G17DCKR	no (buffers)
Resistor	39k	0603	R51, R55	no special		yes
Resistor	68k	0603	R61	no special		yes
Resistor	100k	0603	R53, R54	no special		yes
Capacitor	100p/50V/C OG	0603	C2, C12, C54, C61, C65, C5B, C5T, C7B, C7T,	no special		yes
Capacitor	100p/50V/C OG	0603	C16B, C16T	no special		no
Capacitor	1n/50/COG	0603	C6B, C6T, C21, C22, C51	no special		yes
Capacitor	1n/50/COG	0603	C70B, C70T	no special	capacitors are optional, if not necessary do not assembly	no
Capacitor	10n/50/X7R	0603	C51T, C52T, C53T, C57	no special		yes
Capacitor	100n/50/X7R	0603	C1B, C1T, C2T, C3T, C4, C5, C8B, C8T, C9B, C9T, C12T, C14, C15, C20, C55T, C58, C69	no special		yes

Schematic, Layout and Bill of Material

Capacitor	1μ/25V/X7R	0805	C4B, C4T, C6, C12B, C17T, C18T, C60, C63	no special		yes
Capacitor	4μ7/25V/X7R	1206	C10B, C10T, C11B, C11T, C13B, C13T, C14B, C14T, C50T, C60B, C60T, C61B, C61T, C62, C62B, C62T, C64, C66, C67	Murata		yes
Semiconductor	BAT64-02W	SCD80	D60, D60B, D60T, D61B, D61T, D62B, D62T	Infineon		yes
Semiconductor	MM3Z10VT	SOD323	D6B, D6T	ON Semiconductor		yes
Semiconductor	ZLLS1000	SOT23	D72B, D72T	Zetex		yes
Semiconductor	STTH112U	SMB	D70B, D70T, D71B, D71T	STM		yes
Semiconductor	PMV45EN	SOT23	T62, T63	Philips		yes
Semiconductor	ZMR500FTA	SOT23	IC3B, IC3T, IC4T, IC61	Zetex		yes
Semiconductor	SN74LVC1G14DCKR	SC70	IC1, IC5B, IC5T, IC10	Texas Instrument		yes
Semiconductor	SN74LVC1G02DCKR	SC70	IC1B, IC1T	Texas Instrument	can be replaced by NC7SZ02P5X (Fairchild)	yes
Semiconductor	SN74LVC1G97DCKR	SC70	IC20	Texas Instrument	NAND is SN74LVC1G98DCKR	yes
Semiconductor	TLV431BIDCKT	SC70	IC50T	Texas Instrument		yes
Semiconductor	ZXTN2010Z	SOT89	T1B, T1T	Zetex		yes
Semiconductor	ZXTP2012Z	SOT89	T2B, T2T	Zetex		yes
Semiconductor	IR2085S	SO8	IC60	IR		yes
Semiconductor	HCNW2211#300E	GUL	IC2, IC3, IC12, IC13	Agilent / Avago		
Semiconductor	AD8542ARZ	SOIC8	IC51	Analog Devices		yes
Semiconductor	AD7400YR WZ	SOIC16 (W)	IC50	Analog Devices		yes
Semiconductor	TD350I	SO16	IC2B, IC2T	STM		yes
Connector	Tyco10POL		X1	Tyco	Can be replaced by connector with locker part number: 8-338069-0	yes
Transformer	T60403-D4615-X054		TR60	VAC		yes

Cable connector X1, used for 2ED100E12-F input / output signals has part number: 8-215083-0

4.4 Gate resistors list

Table 5 External gate resistors R_{EXT} are listed bellow (all packages are 2010)

Module	R_{EXT} [Ω]	R70T, R70B, R71T, R71B [Ω]	R72T, R72B, R73T, R73B [Ω]
FF600R06ME3	3,0	1,5	4,7
FF150R12ME3	8,2	6,8	10
FF225R12ME3	3,3	3,3	3,3
FF300R12ME3	2,4	1,5	3,3
FF450R12ME3	1,6	1,0	2,2
FF150R12MS4	7,5	4,7	10
FF225R12MS4	4,7	4,7	4,7
FF300R12MS4	2,7	2,2	3,3

<http://www.infineon.com>